



	CL8.37	CL10.45	CL12.53	CL14.61	CL10.37	CL13.45	CL15.53	CL18.61	
Brine tank capacity	8000	10000	12000	14000	10000	12500	15000	17500	l
Spreading width	3,5 · 7,0 10,5 14,0* · 17,5*	3,5 · 7,0 10,5 14,0* · 17,5*	3,5 · 7,0 10,5 14,0* · 17,5*	3,5 · 7,0 10,5 14,0* · 17,5*	3,5 · 7,0 10,5 14,0* · 17,5*	3,5 · 7,0 10,5 14,0* · 17,5*	3,5 · 7,0 10,5 14,0* · 17,5*	3,5 · 7,0 10,5 14,0* · 17,5*	m
Brine dosage	20 ÷ 80	20 ÷ 80	20 ÷ 80	20 ÷ 80	20 ÷ 80	20 ÷ 80	20 ÷ 80	20 ÷ 80	g/m ²
Cistern lenght	3700	4500	5300	6100	3700	4500	5300	6100	mm

* with additional nozzles



BMU_CL_GB_rev02 - 09/2020 - The technical data and pictures are indicative and not binding.



Sprayer

Water flushing device

Movable front bar for roads washing.

- Spraying width up to 2400 mm (alternatively telescopic width adjustment 2400 – 3600 mm)
- Spraying pressure up to 40 bar (alternatively max pressure 120 bar)
- Assembly on the vehicle front plate
- Drive through vehicle hydraulic installation
- Fed from the CL spreader tanks



Ecosat¹⁰

Latest generation microprocessor control-systems, with maximum flexibility in programming and visualizing the different spreading parameters: width, asymmetry and dosage depending on the vehicle speed.

Six different tools in all-in-one control box



Giletta SpA

Via A. De Gasperi, 1
I-12036 Revello (CN)
tel. +39 0175 258 800
fax. +39 0175 258 825
giletta@buchermunicipal.com

www.buchermunicipal.com

Bucher CL

Modular tanks

Manufactured in recyclable polyethylene constructed to produce a solid structure, whilst still maintaining a flexibility to allow the item to be assembled on the vehicles chassis without limiting its elasticity. The low center of gravity and the presence of breakwater inside the single tanks enable a safe drive in any loading condition, also in rough circuits. Capacity: 2 m³/each. Option for XL tank with higher capacity of 2.5 m³ each.

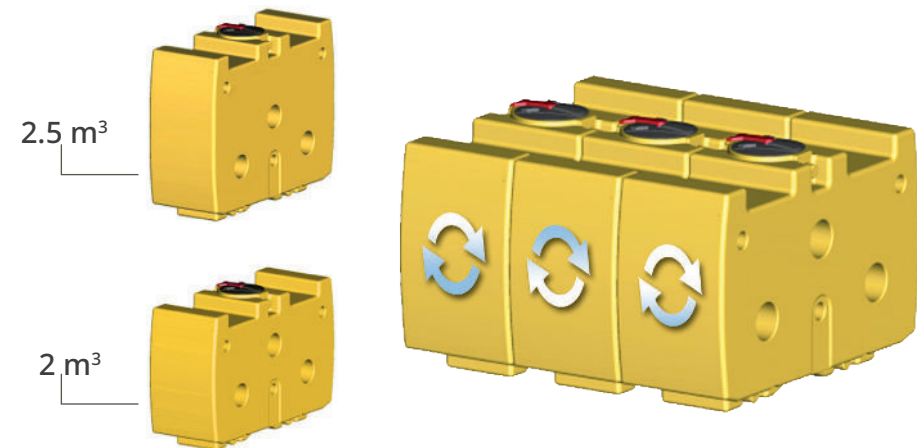

Spreading system

Nine spraying ramps (three on the right, three on the left, and three in the center) consisting of twenty-seven nozzles controlled by electrovalves, which regulate the spraying therefore reaching a max. length of 10.5 m (symmetrical/asymmetrical spraying with steps of 3.5 m).

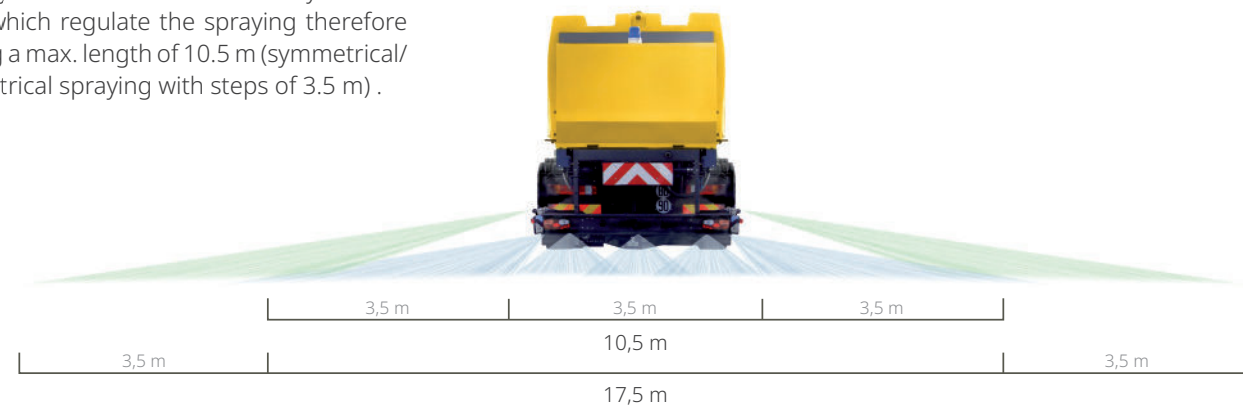

Working scheme

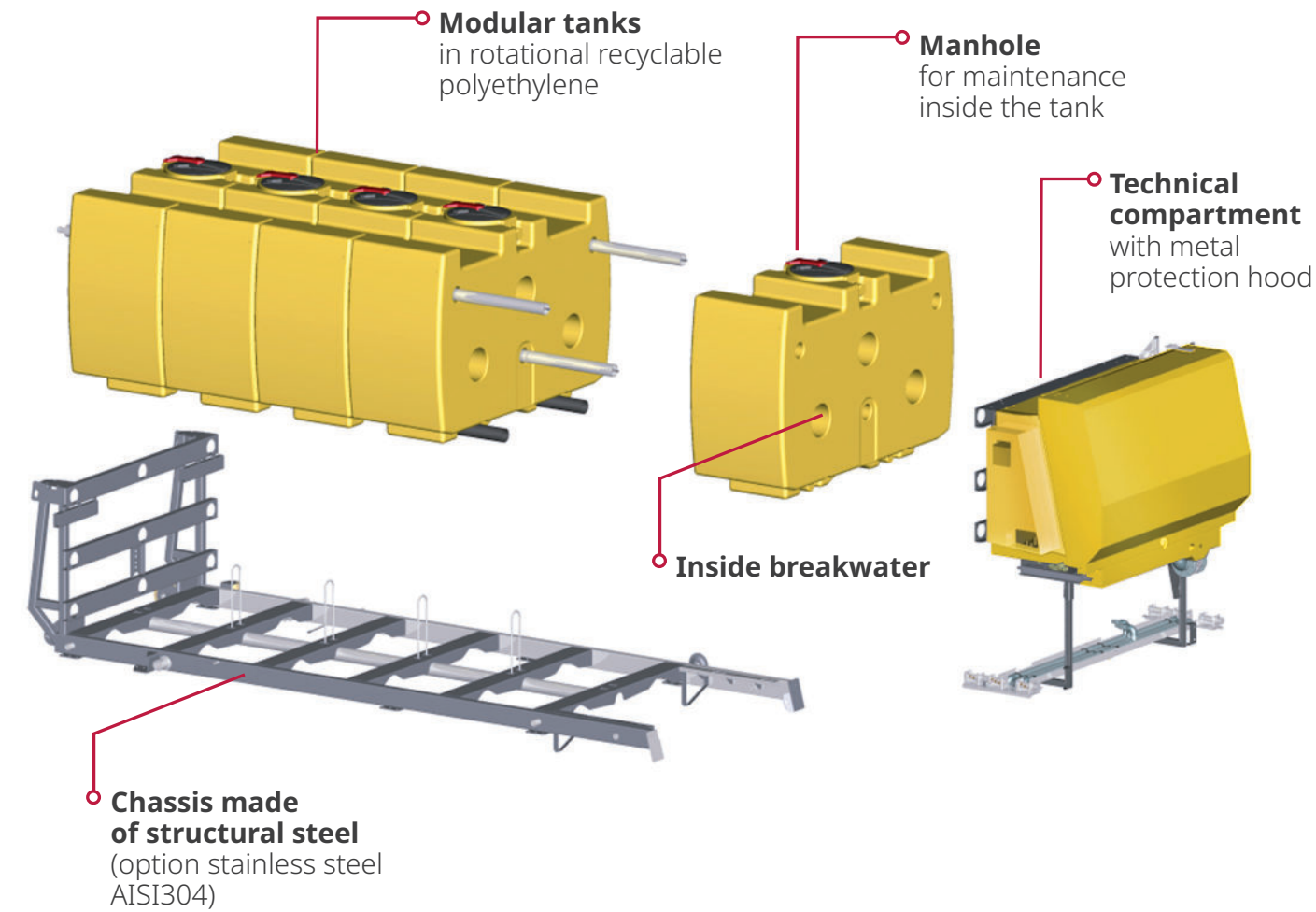

Protected technical compartment

AISI 304 stainless steel rear hood to protect the technical compartment (all the valves, pump, electric and electronic components and Diesel engine, if present). The rear hood opens by means of gas cylinders for easy access.

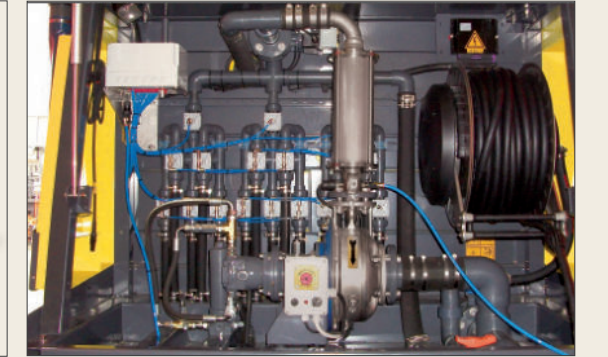

Demount system

Demount system P1

Demount system with galvanized telescopic feet with crank. Higher front feet for easy loading onto vehicles provided with side panels.

Demount system P3

Automatic demount system for tipper, with front rollers and feet fitting into the spreader. Unloading can be done automatically from the driver's cab.

Demount system P4

Demount system for hook-lift complete of slide, protection guard for the vehicle platform and adjustable height rear rollers.



Feeding systems



Hydraulic

Throughout the vehicle hydraulic system are features that comply with the European Standards EN15431.



Auxiliary engine

Driven by an air-cooled (A/D) or liquid-cooled Diesel engine.

Main options on request



Hose and nozzle

Option of wander hose with nozzle system (delivery 15 l/min.) available. Alternatively a high pressure system (delivery 15 l/min. - pressure 150 bars)

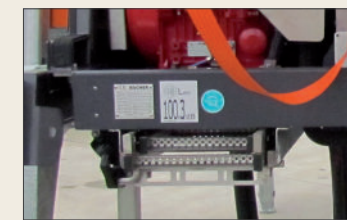

Ladder

Ladder for safe access onto the rear right side in stainless steel AISI 304.



Recycle system

Pump recycle available through PVC pipes to avoid brine sedimentations.

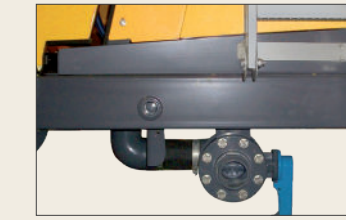

Loading valve

Tanks filling with PVC hose and throttle. From the same tank attachment can be carried out the gravity unloading.

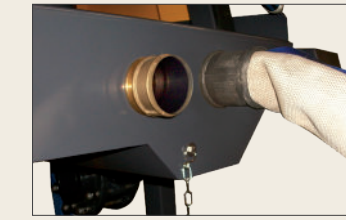

Hydrant valve

The connecting valve placed on the vehicle rear side, for optional nozzle or hydrants, is protected by a metal lid with screw locking.



"Overflow" unloading

Safety system of unloading device to avoid tank overflow is in place.

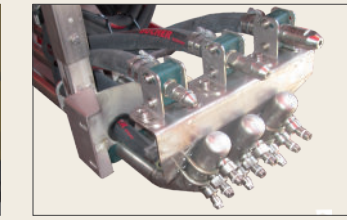

Six spraying nozzles

As option six spraying nozzles (three on the left side and three on the right one) enable to reach a max. length up to 17.5 m.